

Remote Mounting for SRD991 and SRD960

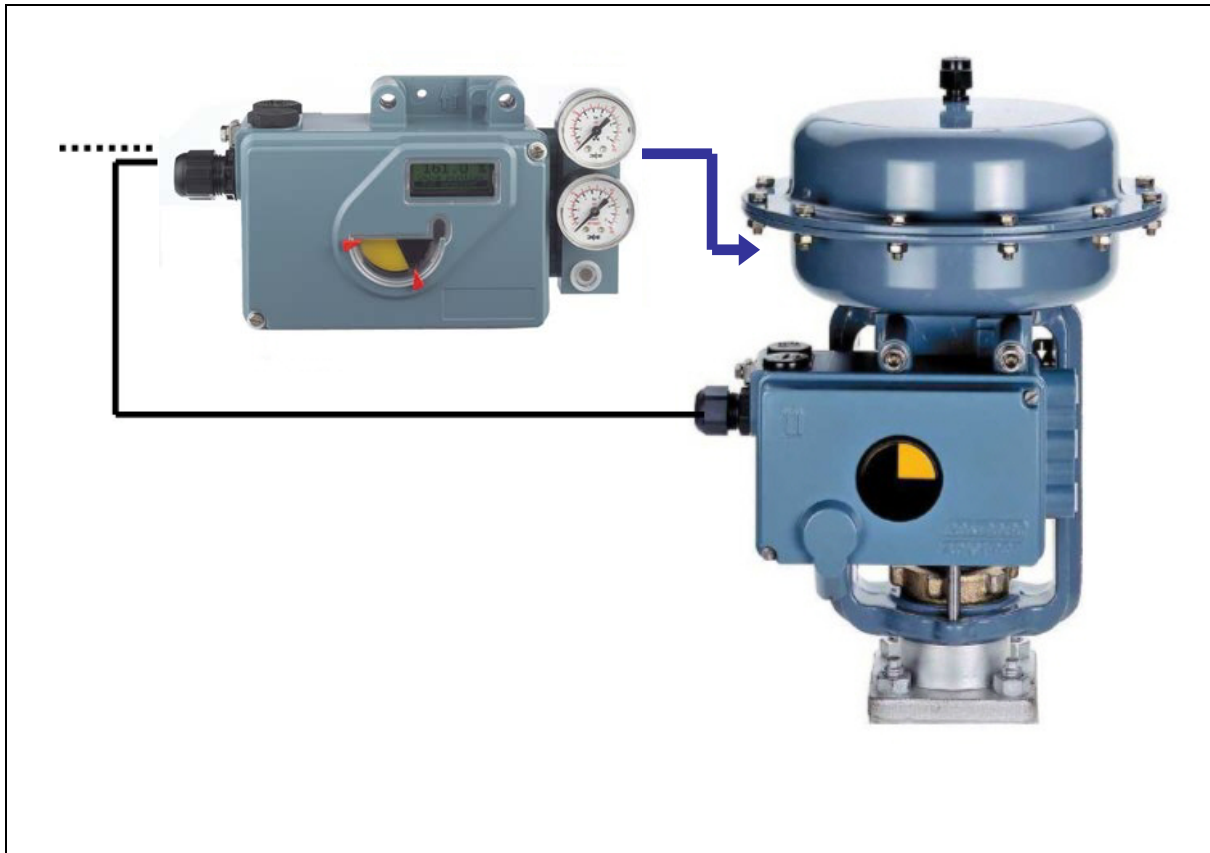

This remote application is used in applications where high temperatures or vibration are present and can result in negative influences to the control. It can also be used in places not easy to reach, to ensure an easier handling of the unit, or for cylinder with large stroke.

The Positioner SRD991 / SRD960 (Remote unit) is mounted far away from the valve or cylinder in a safe environment.

The Potentiometer unit is mounted on the valve or cylinder. This potentiometer unit can be made of a derivate version of our SRI990 /SRD960 positioner (only potentiometer in the housing) or of an external potentiometer like a linear potentiometer for application onto cylinder for example.

FEATURES

- Remote unit (unit mounted far away from the valve) with all standard features:
 - Intrinsic Safety (SRD991) or Explosion Proof (SRD960)
 - All protocol of communication
 - Option board (4-20mA position feedback, binary in or outputs)
- Potentiometer unit made of a SRD housing and potentiometer inside and optional features such as Limit Switches.
- Potentiometer unit made of a SRD housing in Intrinsically safe version and potentiometer unit can withstand temperatures of up to 100°C (212°F) on standard.
- Potentiometer unit can be made of linear potentiometer for application on cylinder or very small valve.

Potentiometer unit made of a SRD housing and a heavy duty potentiometer inside

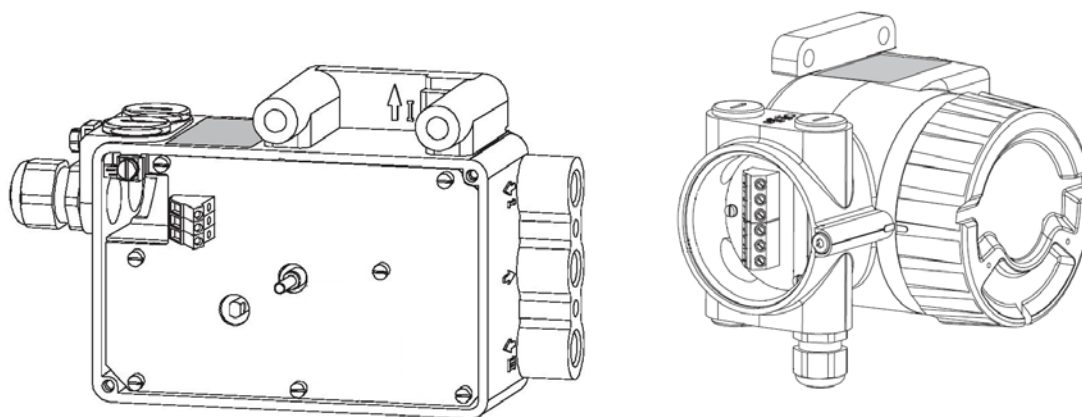

1 FEATURES

For severe applications

Recommend for strong vibrations and for ambient temperature up to 100°C (212°F) only for the intrinsically safe version (SRI990 potentiometer unit).

This type of mounting is also recommended when the valve is near strong magnetic field or in presence of energizing radiation.

Easy to use

The Potentiometer unit can be mounted easily onto any actuator (linear and rotary) of any size thanks to the wide range of attachment kit available. The same attachment kits than the SRD positioner is used.

All the configuration is very easy to do with our VALcare or Valve Monitor (DTMs) to install into any host supporting FDT-DTM. The configuration windows are simple and intuitive thank to univocal text and a clear presentation.

2 MOUNTING FOR INTRINSIC SAFETY AREA:

Mounting in Intrinsic Safety area or when no electrical certification is requested



Mounting made of :

Potentiometer unit SRI990-TXMxxxxx-UH

- On the potentiometer unit can be mount limit switches and the unit can be ATEX certified.
- The option U (without pneumatic connection) and H (potentiometer unit) have to be selected.

Remote unit SRD991-xxxDxxxxNx-Vxx

- The option board must be D (for remote mounting potentiometer entry)
- The remote unit cannot be equipped of limit switches.
- The remote unit can be ATEX certified

In case an other option board as D is requested (for example position feedback 4-20mA) a specific cabling should be done, please consult us.

Attention : Cable between the 2 units not supplied by Foxboro Eckardt.

For the Remote unit is recommend to order a EBZG-K5 for a mounting onto pipe of diameter from 35 to 60mm

For all specification please refer you the PSS EVE0105 E for SRD991 unit and PSS EVE0107 A for the SRI990 unit

ELECTRICAL CONNECTION

Electrical connection on Remote unit:

	Connections on SRD991-xxxDxxxxNx-Vxx ...		
Line ID	16	15	14
Cable	Line 3	Line 2	Line 1

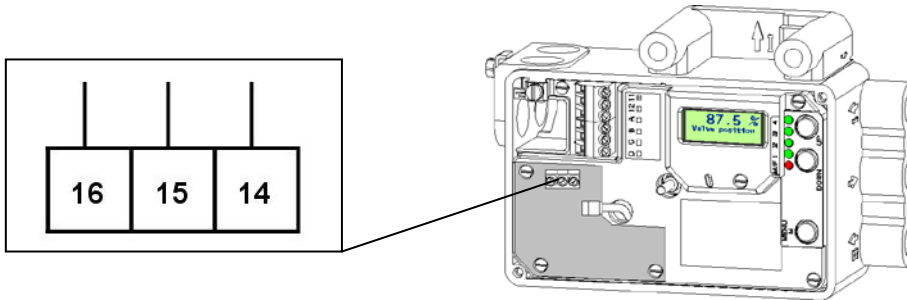

Electrical connection on remote unit:

	Connections on SRI990-TXMxxxxx-UH		
Line ID	16	14	15
Cable	Line 3	Line 1	Line 2

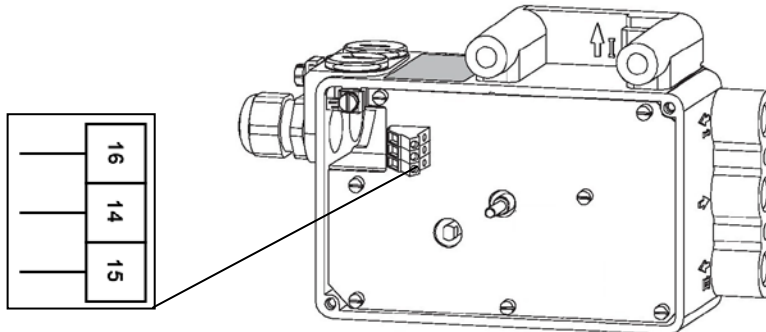

WIRING REQUIREMENTS

If the following requirements are observed, the set-up is insensitive against electrical disturbances caused by high electromagnetic fields, EMC and HF-radiation.

Cable Length

Max. Length: 10 m (32 ft)

Cable Specification: (not supplied by Foxboro Eckardt)

- The requirements in the product specification sheet for the electrical connection of the SRD991 (PSS EVE0105 E) and SRI990 (PSS EVE0107 A) need to be observed
- 3-wire twisted pair, shielded
- shield needs to be connected on both ends to the internal ground
- shield endings need to be kept very short when connecting to the ground
- a HF cable gland is not required

3 MOUNTING FOR EXPLOSION PROOF AREA:

Mounting in Explosion Proof Area Exd

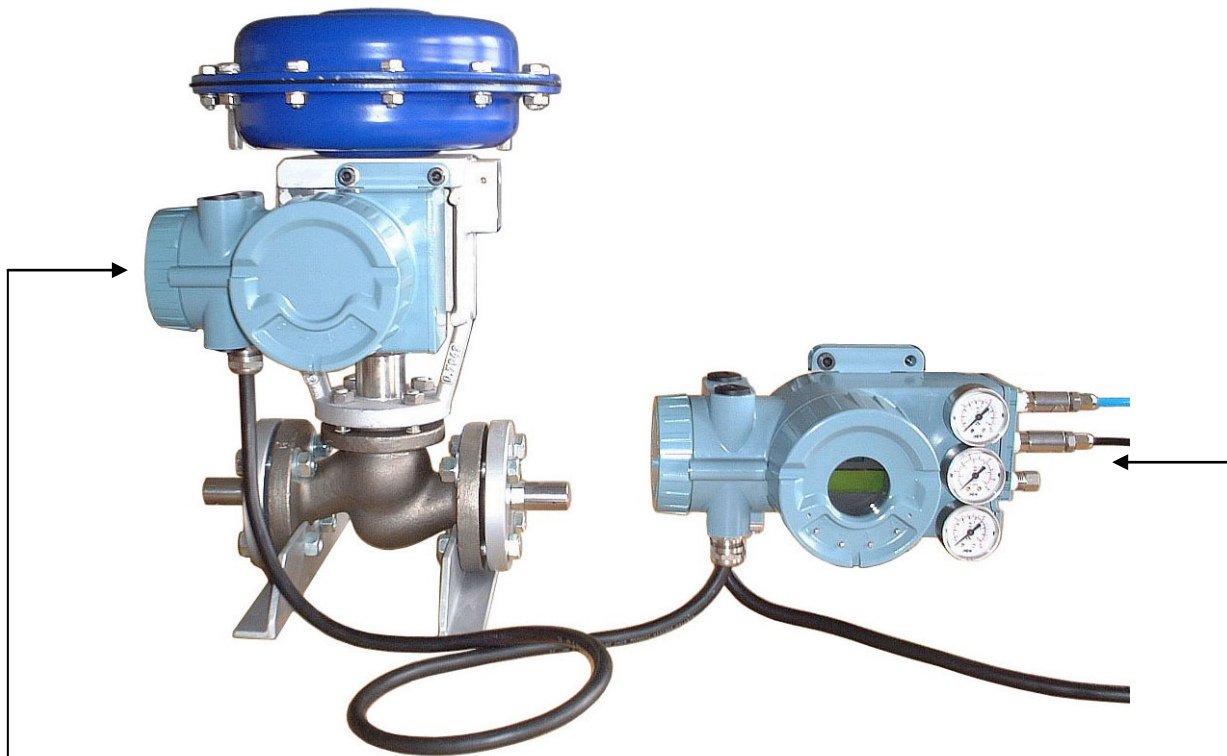

Mounting made of :

Potentiometer unit SRD960-TXNSxXxEDZFS-H

- The potentiometer unit is ATEX Exd certified.
- The option H has to be selected (potentiometer unit for remote mounting)

Remote unit SRD960-xxDxxxxEDZFx-x

- The option board must be D (for remote mounting potentiometer entry)
- The remote unit cannot be equipped of limit switches or other option board other than code D.
- The remote unit is ATEX Exd certified.

Attention : Cable between the 2 units not supplied by Foxboro Eckardt.

For the Remote unit is recommend to order a EBZG-K5 for a mounting onto pipe of diameter from 35 to 60mm

For all specification please refer you the PSS EVE0109 A of the SRD960

ELECTRICAL CONNECTION

Electrical connection on Remote unit:

	Connections on SRD960-xxD...			
Conduit	A	B	C	D
Line ID	13	14	15	16
Cable	Not in use	Line 1	Line 2	Line 3

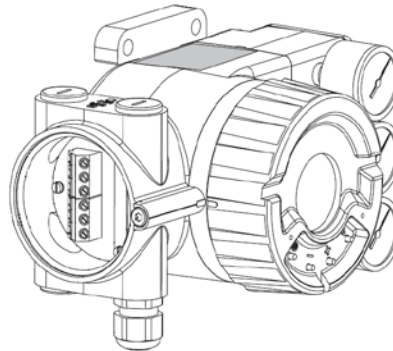

Electrical connection on remote unit:

	Connections on SRD960-TXN...-H		
Line ID	14	15	16
Cable	Line 1	Line 2	Line 3

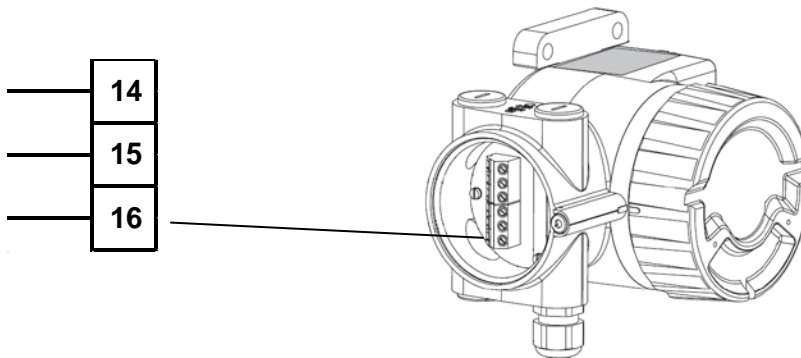

WIRING REQUIREMENTS

If the following requirements are observed, the set-up is insensitive against electrical disturbances caused by high electromagnetic fields, EMC and HF-radiation.

Cable Length

Max. Length: 10 m (32 ft)

Cable Specification: (not supplied by Foxboro Eckardt)

- The requirements in the product specification sheet for the electrical connection of the SRD960 (PSS EVE0109 A) need to be observed
- 3-wire twisted pair, shielded
- shield needs to be connected on both ends to the internal ground
- shield endings need to be kept very short when connecting to the ground
- a HF cable gland is not required

Additional Documentation for these products:**Technical Information of Attachment Kits for Positioners**

TI EVE0011 A Overview of Attachment Kits of all positioners on actuators/valves of different manufacturers

SRD991**Quick Guide:**

QG EVE0105 A/B Extract of Master Instruction for an easy to use, easy understandable and fast start-up. This document highlights the most important.

Product Specification Sheet:

PSS EVE0105 E SRD991 -all versions-

Master Instructions:

MI EVE0105 E SRD991 -all versions-

Technical Information for Fieldbus-Communication:

TI EVE0105 P SRD991/960 -PROFIBUS-PA

TI EVE0105 Q SRD991/960 -FOUNDATION Fieldbus H1

Instruction for HART-Communication:

MI EVE0105 B HART with Hand-Held Terminal

SRI990**Quick Guide:**

QG EVE0107 A Extract of Master Instruction for an easy to use, easy understandable and fast start-up. This document highlights the most important.

Product Specification Sheet:

PSS EVE0107 A SRI990 -all versions-

Master Instructions:

MI EVE0107 A SRD991 -all versions-

Subject to alterations - reprinting, copying and translation prohibited. Products and publications are normally quoted here without reference to existing patents, registered utility models or trademarks. The lack of any such reference does not justify the assumption that a product or symbol is free.

FOXBORO ECKARDT GmbH
Pragstrasse 82
D-70376 Stuttgart
Germany
Tel. + 49(0)711 502-0
Fax + 49(0)711 502-597
<http://www.foxboro-eckardt.de>

i n v e n s y s
Operations Management

DOKT 557 535 029

ECKARDT S.A.S.
20 rue de la Marne
F-68360 Soultz
France
Tel. + 33 (0)3 89 62 15 30
Fax + 33 (0)3 89 62 14 85
<http://www.foxboro-eckardt.com>